



Vibration Switch CVS 100 EEx d II C T6

Data Sheet

CHARACTERISTICS

- low cost vibrationcontrol
- vibration velocity or vibration displacement
- simple version
- easy installation
- 2 adjustable level detectors
- analog output 0/4..20 mA
- stainless steel casing



General

The vibration switch CVS 100 EEx allows a low-priced realisation of vibration control for stand-alone machines and auxiliary aggregates (e.g. fans, pumps, centrifuges, mills, gears, etc.), on whose functions important big-Installations or process-bounds are depending. Among other things it allows observation according to VDI 2056 and ISO 2372.

Utilized for this are the Vibrations of important machine parts (pillowblocks, foudations, casings) covered by rugged velocity feeders in electrical signals and processed and assessed with integrated electronics.

This signal- and adjust electronics is fitted together with the velocity feeder into a stainless steel casing, fitted directly onto the machine to be observeate.

Two independent adjustable level detectors with eligible response delay are allowing the volt free signaling of „warning“ and „alarm“ via appropriate assigned relays.

FUNCTIONAL DISCRIPTION

The signal of the velocity feeder is passed via a band-pass filter (10-1000 Hz) and is amplified in an amplifier up to the utilizing required level. An additional integrator enables displacement controlling alternative.

The measuring ranges' and measuring units' selection is made by jumper. The DC-output signal available after the rectifying is calibrated in RMS. It has an effect on two adjustable level detectors, whose response time is set by jumpers either to 1sec. or to 5sec. The assigned relays' change-over contacts enable the signal-circuit assembly (warning/alarm).

TECHNICAL DATA

Measuring direction:

vertical or horizontal
(please take into account when ordering)

Amplifier:

AC-Amplifier with rectifier and filter

Measuring ranges:

Velocity: 2, 5, 10, 20, 50 [mm/s] (effective)
Displacement: 20, 50, 100, 200, 500 [μ mp]

Frequency range: 10 Hz .. 1000 Hz

Output signal: 0/4 .. +20 mA $R_{Last} \leq 500 \Omega$

proportional velocity or displacement, calibrated in effective [mm/s] or peak [μ mp]

Level detectors:

2 pieces, limits adjustable in range of 5 .. 100% of respective measuring range end (Fail-Safe function, Relays normally energized)

Time delay:
adjustable 1 sec. or 5 sec.

Relay contact safe load (change-over contact):
Turn-on Voltage max.: 150 VDC / 125 VAC
Switching Current max.: 1A
Constant limited current max.: 1A
Rupturing capacity max.: 30W / 60VA

Supply:

Voltage: 24VDC +/-20% ca. 30mA
No galvanic separation

Temperature range:

-20 .. +70°C working temperature
-30 .. +70°C storage range

Vibration Switch CVS 100 EEx d II C T6

Data Sheet

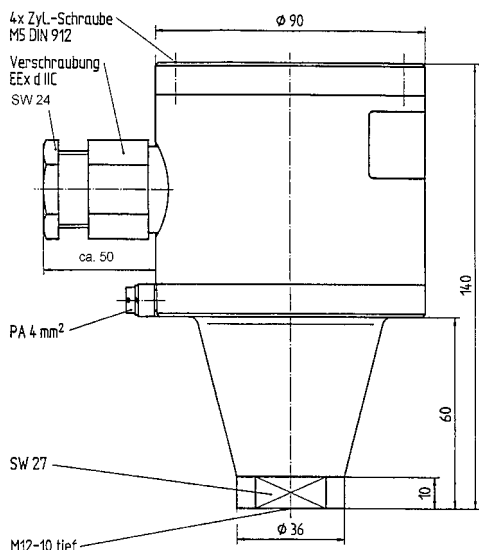

- Casing dimension:** 140 x 90 mm (height x diameter)
Material: stainless steel (1.4305)
Mounting: M12, 10 mm deep, wrench 27, starting torque 10Nm
Screwed cable gland: M20 x 1,5; AX-A-M20, ATEX 13150 U
Protection class: IP 65
 PTB 03 ATEX 1051
Weight: ca. 3,3 kg

